

Parts Manual

EC Series Combination Blanket/Fluid Warmer 13.3 and 18.5 cubic foot models

MN-39808 • Rev 15 • 12/2022

Table of Contents

Full View3
Interior View4
Electrical Chassis5
Power Inlet Assembly6
Interface Assembly7
Fan Assembly8
Cavity Sensors9
Accessories	10
Service Kit for Heat Pad Replacement	10
Wiring Diagram	11-12

Full View

Item	Description	Part	Qty
1	Assembly, Interface, EC1350BL/1850BL	5029706	1
2	Element, Heater Pad, 16" X 12", 13.3 ft ³	EL-39472	2
	Element, Heater Pad, 13.3 ft ³	EL-46555	2
	Element, Heater Pad, 16" X 12", 18.5 ft ³	EL-36692	6
3	Caster, 5" Wheel, W/ Brake, 18.5 ft ³	CS-35290	2
	Feet, Leveling, 18.5 ft ³	FE-28909	4
3a	Assembly, Base, Seismic, 13.3 ft ³	5030489	2
4	Caster, 5" Wheel, Swivel, 18.5 ft ³	CS-24875	2
	Fitting, Threaded Tube Insert, 18.5 ft ³	FT-28910	4
5	Assembly, Door, Window RH, 13.3 ft ³	5027916	1
	Assembly, Door, Window LH, 13.3 ft ³	5029819	1
	Assembly, Door, Window RH, Lock, 13.3 ft ³	5029834	1
	Assembly, Door, Window LH, Lock, 13.3 ft ³	5029833	1
	Assembly, Door, Solid LH, Lock, 13.3 ft ³	5029840	1
	Assembly, Door, Solid LH, 13.3 ft ³	5029837	1
	Assembly, Door, Solid RH, Lock, 13.3 ft ³	5029839	1
	Assembly, Door, Solid RH, 13.3 ft ³	5029836	1
	Assembly, Door, Window RH, 18.5 ft ³	5025132	1
	Assembly, Door, Window LH, 18.5 ft ³	5025405	1
	Assembly, Door, Window RH, Lock, 18.5 ft ³	5025410	1
	Assembly, Door, Window LH, Lock, 18.5 ft ³	5025411	1
	Assembly, Door, Solid LH, Lock, 18.5 ft ³	5025431	1
	Assembly, Door, Solid RH, Lock, 18.5 ft ³	5025430	1
	Assembly, Door, Solid RH, 18.5 ft ³	5025412	1
6	Assembly, Door, Window, 13.3 ft ³	5027915	1
	Assembly, Door, Solid, 13.3 ft ³	5029835	1
	Assembly, Door, Window, Lock, 13.3 ft ³	5029820	1
	Assembly, Door, Solid, Lock, 13.3 ft ³	5029838	1
	Assembly, Door, Window, 18.5 ft ³	5025133	1
	Assembly, Door, Solid, 18.5 ft ³	5025433	1
	Assembly, Door, Window, Lock, 18.5 ft ³	5025434	1
	Assembly, Door, Solid, Lock, 18.5 ft ³	5025435	1
7	Panel, Back, 13.3 ft ³	1031741	1
	Panel, Back, 18.5 ft ³	1024790	1
8	Panel, Top Cover, 13.3 ft ³	1031785	1
	Panel, Top Cover, 18.5 ft ³	1024924	1
9	Panel, Top Trim, 13.3 ft ³	1031774	1
	Panel, Top Trim, 18.5 ft ³	1024923	1
10	Panel, Side, RH, 13.3 ft ³	1031746	1
	Panel, Side, RH, 18.5 ft ³	1024789	1
11	Panel, Side, LH, 13.3 ft ³	1031746	1
	Panel, Side, LH, 18.5 ft ³	1025449	1
12	Panel, Bottom, 18.55ft ³	5025101	1
12a*	Panel, Toe Kick, 13.3 ft ³	1031542	1
13	Insulation, Package, 13.3 ft ³	5029803	1
13	Insulation, Package, 18.5 ft ³	5025306	1

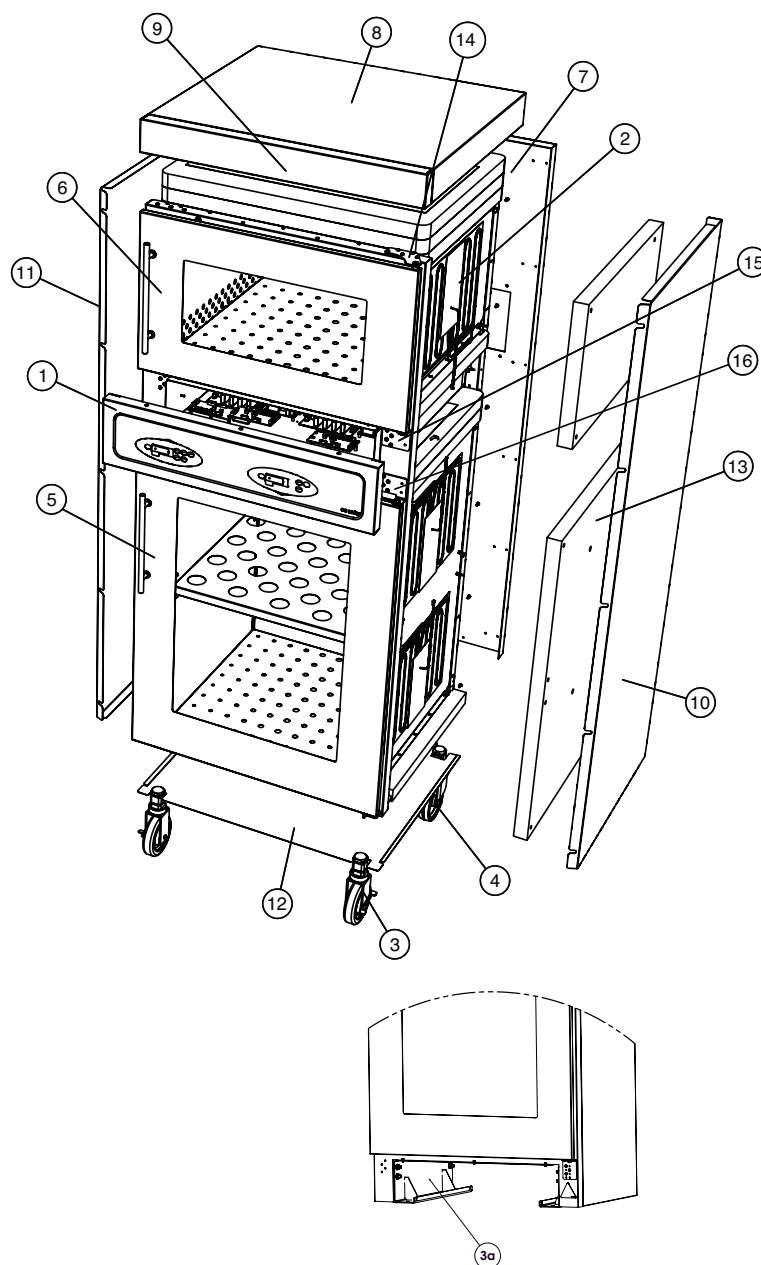

Item	Description	Part	Qty
14	Assembly, Hinge, Upper, RH, 18.5 ft ³	5025491	1
	Assembly, Hinge, Upper, LH, 18.5 ft ³	5025492	1
15	Assembly, Hinge, Lower RH, Upper, LH, 13.3 ft ³	1031863	2
15	Assembly, Hinge, Lower RH, Upper, LH, 18.5 ft ³	5025493	1
16	Assembly, Hinge, Lower LH, Upper, RH, 13.3 ft ³	1031864	2
16	Assembly, Hinge, Lower LH, Upper, RH, 18.5 ft ³	5025494	1
17*	Pin, Press Fit Hinge, 13.3 ft ³	PI-29192	4

* Not Shown

Serial number is required for all inquiries.

Part numbers and drawings are subject to change without notice.

Service Parts

Interior View

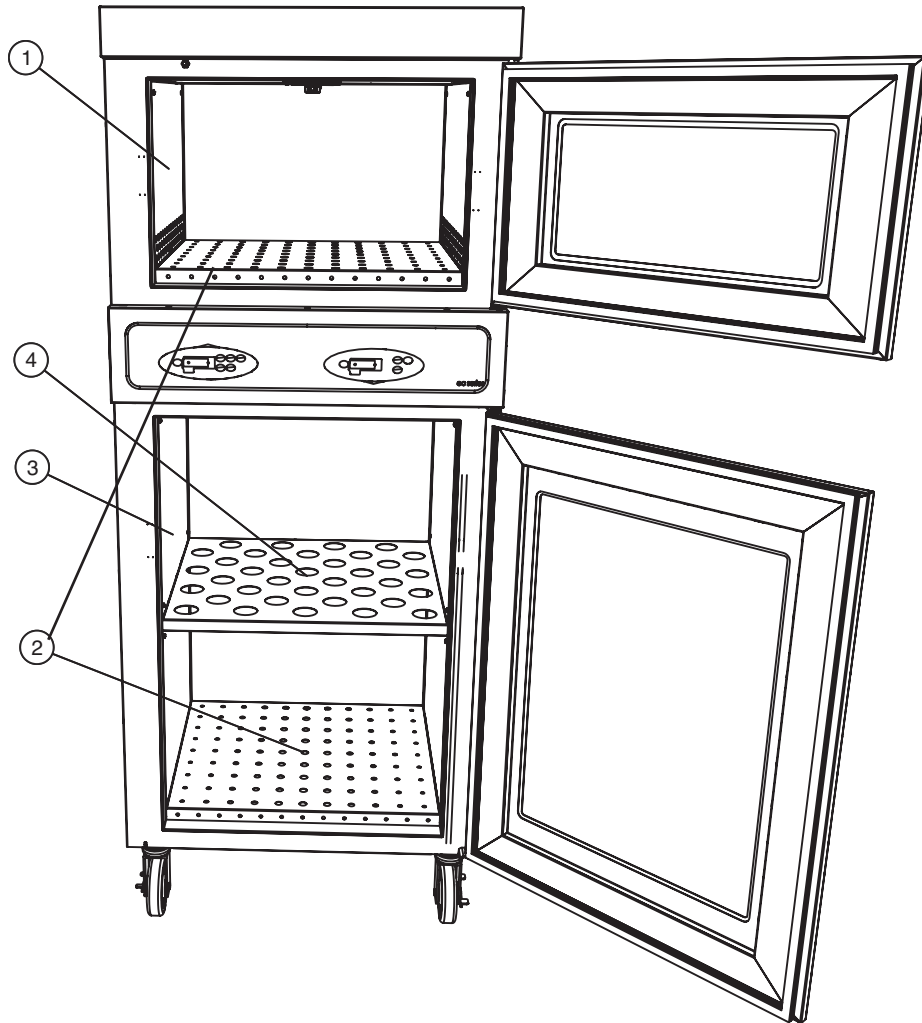

Item	Description	Part	Qty
1	Panel, Insert Side, Fluid Cavity, 13.3 ft ³	1031538	2
	Panel, Insert Side, Fluid Cavity, 18.5 ft ³	1024771	2
2	Panel, Shelf, Bottom, 13.3 ft ³	1032029	2
	Panel, Shelf, Bottom, 18.5 ft ³	1024766	2
3	Panel, Insert Side, Blanket Cavity, 13.3 ft ³	1031536	2
	Panel, Insert Side, Blanket Cavity, 18.5 ft ³	1025073	2
4	Panel, Shelf, 13.3 ft ³	1031787	1
	Panel, Shelf, 18.5 ft ³	1024763	1
5*	Clip, Shelf	1026148	4

* Not Shown

Serial number is required for all inquiries.

Part numbers and drawings are subject to change without notice.

Electrical Chassis

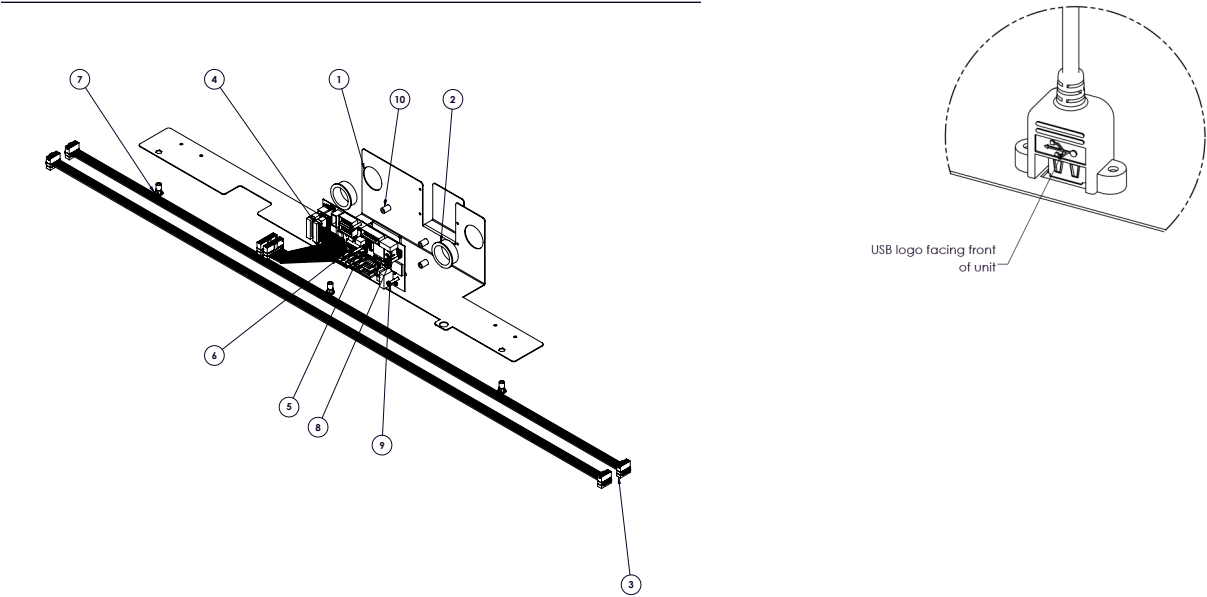

Item	Description	Part	Qty
1	Bracket, Control Board	1037340	1
2	1 1/8" Snap Bushing	BU-3378	2
3	Cable, Relay Board	CB-35193	2
4	Cable, 12" Display	CB-38543	2
5	Board, circuit, Control	CC-39754	1
6	Shunt jumper	CR-36952	5
7	Nut, Hex insert M4	NU-37267	3
8	Screw, M3-0.5 x 16MM, PH HD	SC-35824	4
9	Screw, M3x0.5x25MM Pan	SC-36661	1
10	Spacer, 1/4" DIA x 3/8" Nylon	SP-29425	5

Serial number is required for all inquiries.

Part numbers and drawings are subject to change without notice.

Service Parts

Power Inlet Assembly

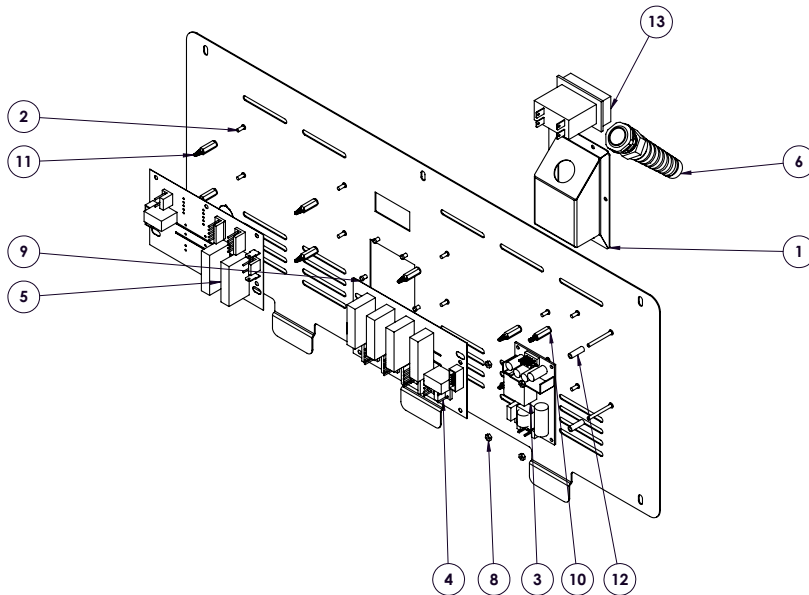

Item	Description	Part	Qty
1	Bracket, Cord	1035776	1
2	Assembly, Weld Stud	5032473	1
3	Power Supply, 20W	BA-34965	1
4	Relay Board, 4-Zone, 120V	BA-39302	1
	Relay Board, 4-Zone, 230V	BA-39304	1
5	Relay Board, 2-Zone, 120V	BA-46669	1
	Relay Board, 2-Zone, 230V	BA-46670	1
6	Bushing, Straight, Strain Relief	BU-34836	1
7	Envelope, Press on, CVLS, HLVS	EV-28115	1
8	Nut, M3-0.5 Hex Nut	NU-22285	4
9	Rivet, Blind, #44, STNLS	RI-2100	6
10	Spacer, Stand Off Male-Female	SP-46570	2
11	Spacer, Stand Off Female-Board	SP-46671	8
12	Spacer, M3	SP-47752	2
13	Switch, 20 Amp C.B.	SW-33858	1

Serial number is required for all inquiries.

Part numbers and drawings are subject to change without notice.

Interface Assembly

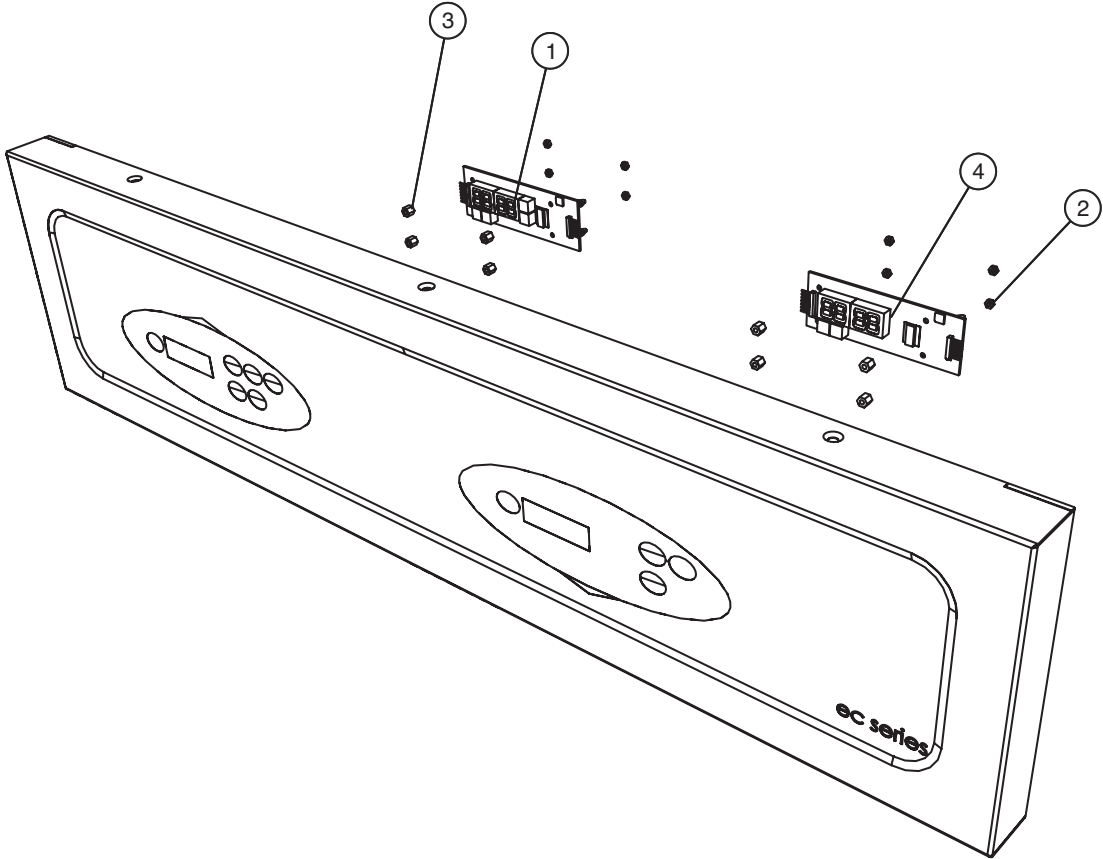

Item	Description	Part	Qty
1	Circuit Board, Fluid Display	BA-35309	1
2	Nut, M3-0.5 Hex Nut	NU-22285	8
3	Spacer, 1/4" Hex, Nylon	SP-33707	8
4	Circuit Board, Display	BA-34868	1

Serial number is required for all inquiries.

Part numbers and drawings are subject to change without notice.

Service Parts

Fan Assembly

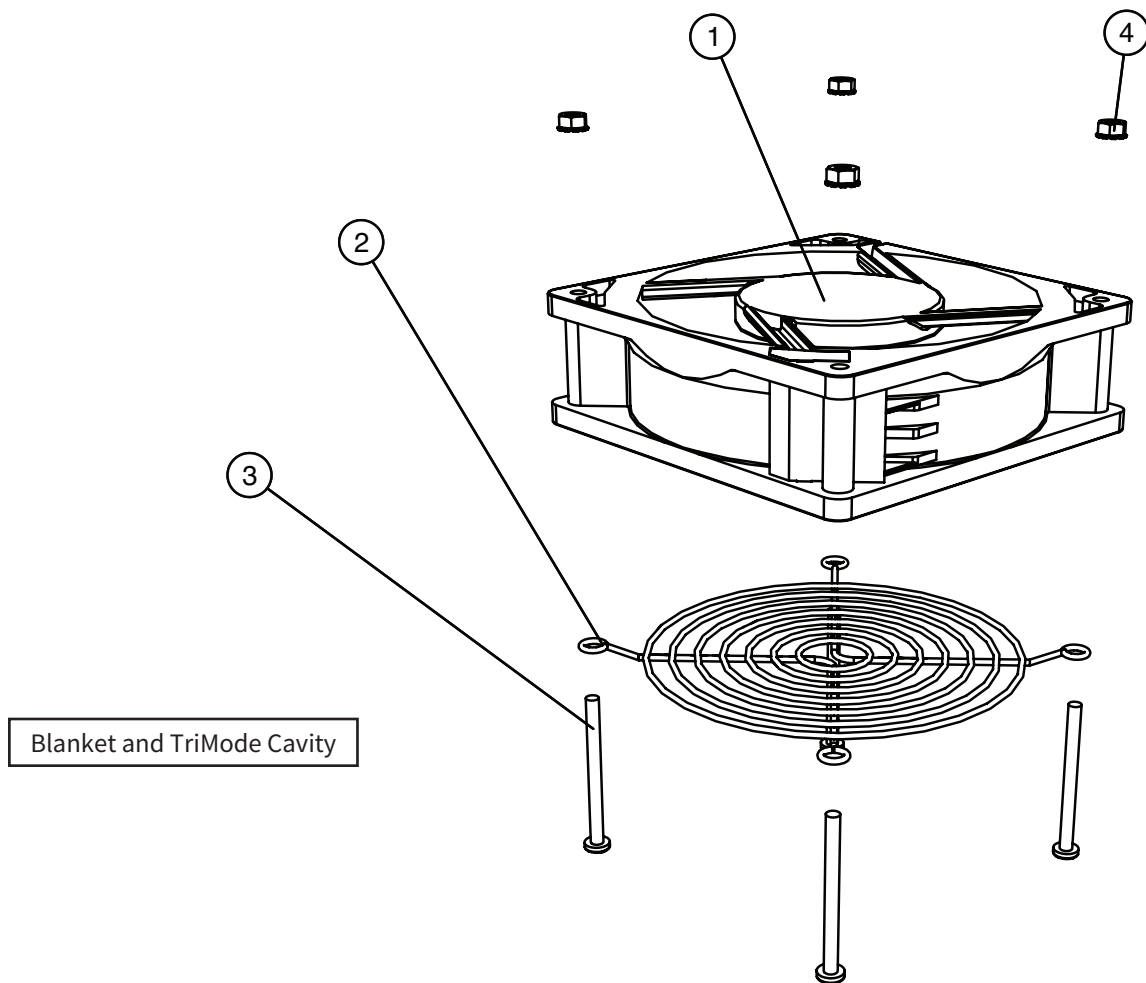

Blanket and TriMode Cavity

Item	Description	Part	Qty
1	Fan, Axial, 120mm, 100-240V	FA-39406	1
2	Fan Guard	1035493	1
3	Screw, M4 X 0.7 X 50mm Pan	SC-29261	4
4	Nut, M4, Keps, Zinc Plated	NU-36319	4

Serial number is required for all inquiries.

Part numbers and drawings are subject to change without notice.

Cavity Sensors

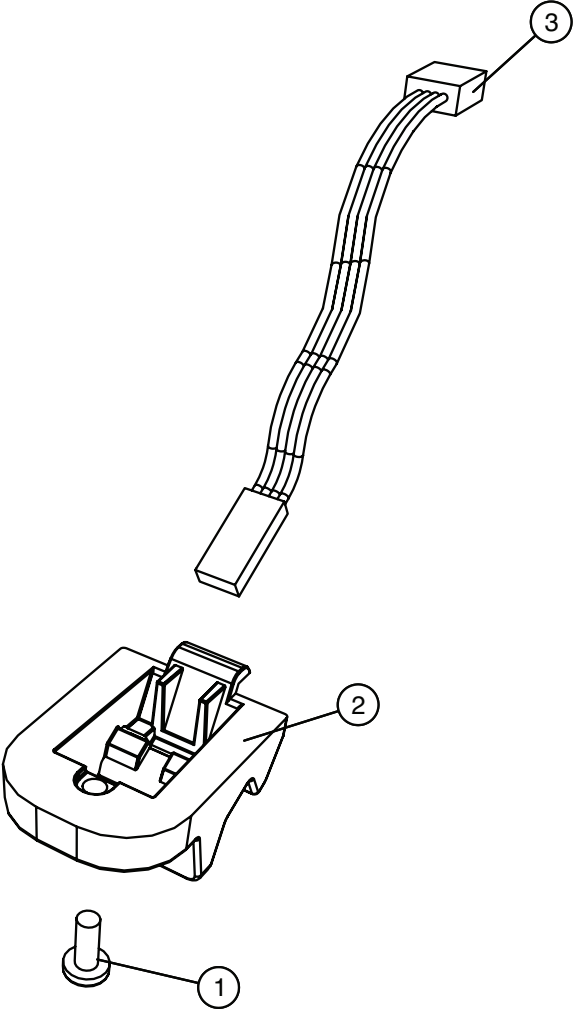

Item	Description	Part	Qty
1	Screw, M4 X 0.7 X 10mm Pan	SC-22273	2
2	Sensor Mounting Block	BK-29882	2
3	Probe, Dual J-Type Termostor,48" Epoxy Housing	PR-38590	2

Serial number is required for all inquiries.

Part numbers and drawings are subject to change without notice.

Service Parts

Accessories

Description	Part No.	Part No.
	13.3 cu. ft.	18.5 cu. ft.
Built-in trim kit	5029906	5027709
Foot Kit	N/A	5021814
Floor mounting hardware	5032891	N/A
Lock for door handle	LK-36962	LK-36962
Shelf Kit	5031266	5031264
TempTrak Transmitter & Probe Kit 900MHZ	5032535	5032535

Service Kit for Heat Pad Replacement

Description	Part No.
Service Kit for EL-36692	5027888
Service Kit for EL-46555	5031024
Service Kit for EL-39472	5027940

Serial number is required for all inquiries.

Part numbers and drawings are subject to change without notice.

Wiring Diagram 13.3 Cu. Ft Combination warmer

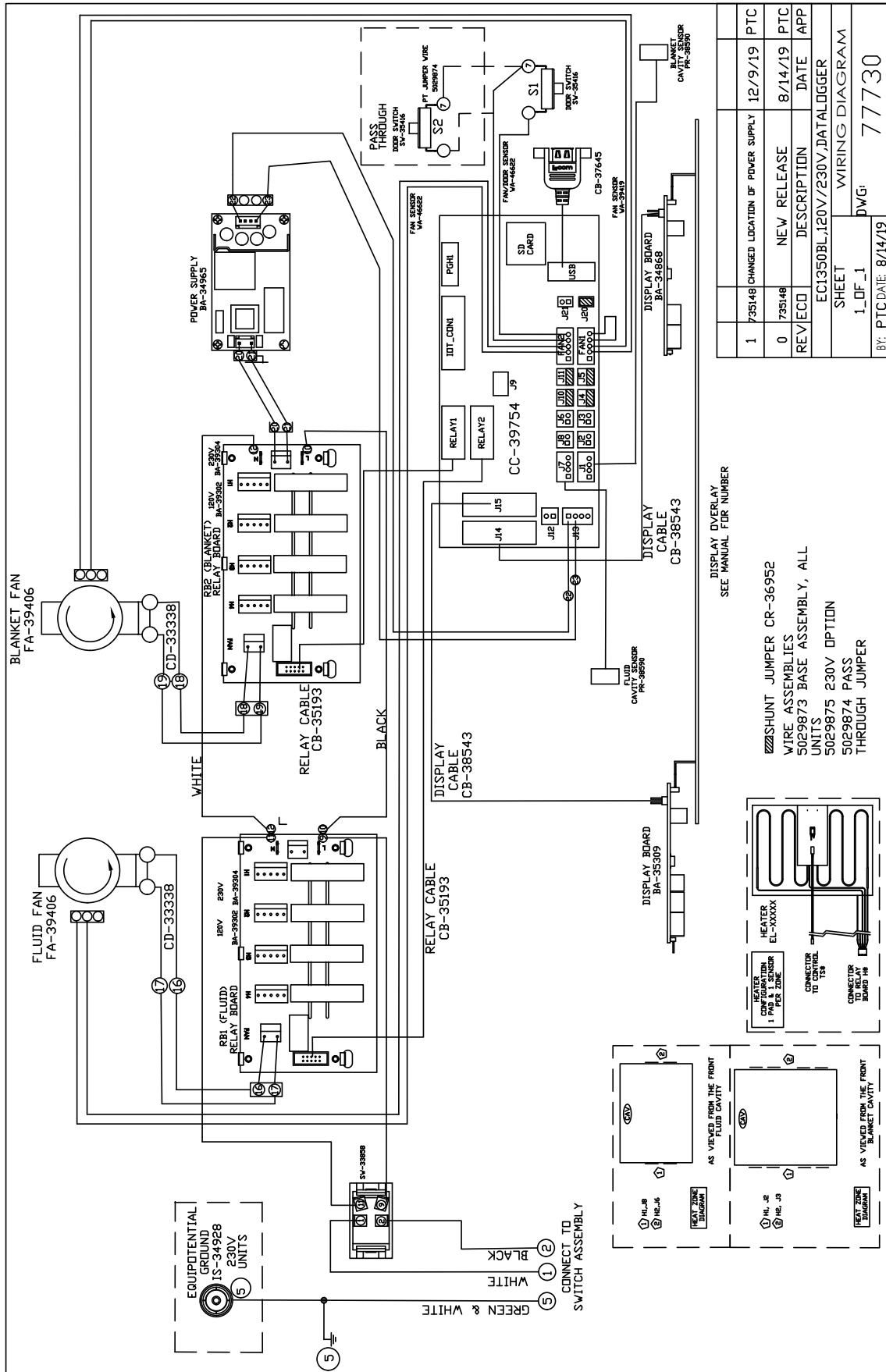

Serial number is required for all inquiries.

Part numbers and drawings are subject to change without notice.

Wiring Diagram 18.5 cu. Ft Combination Warmer

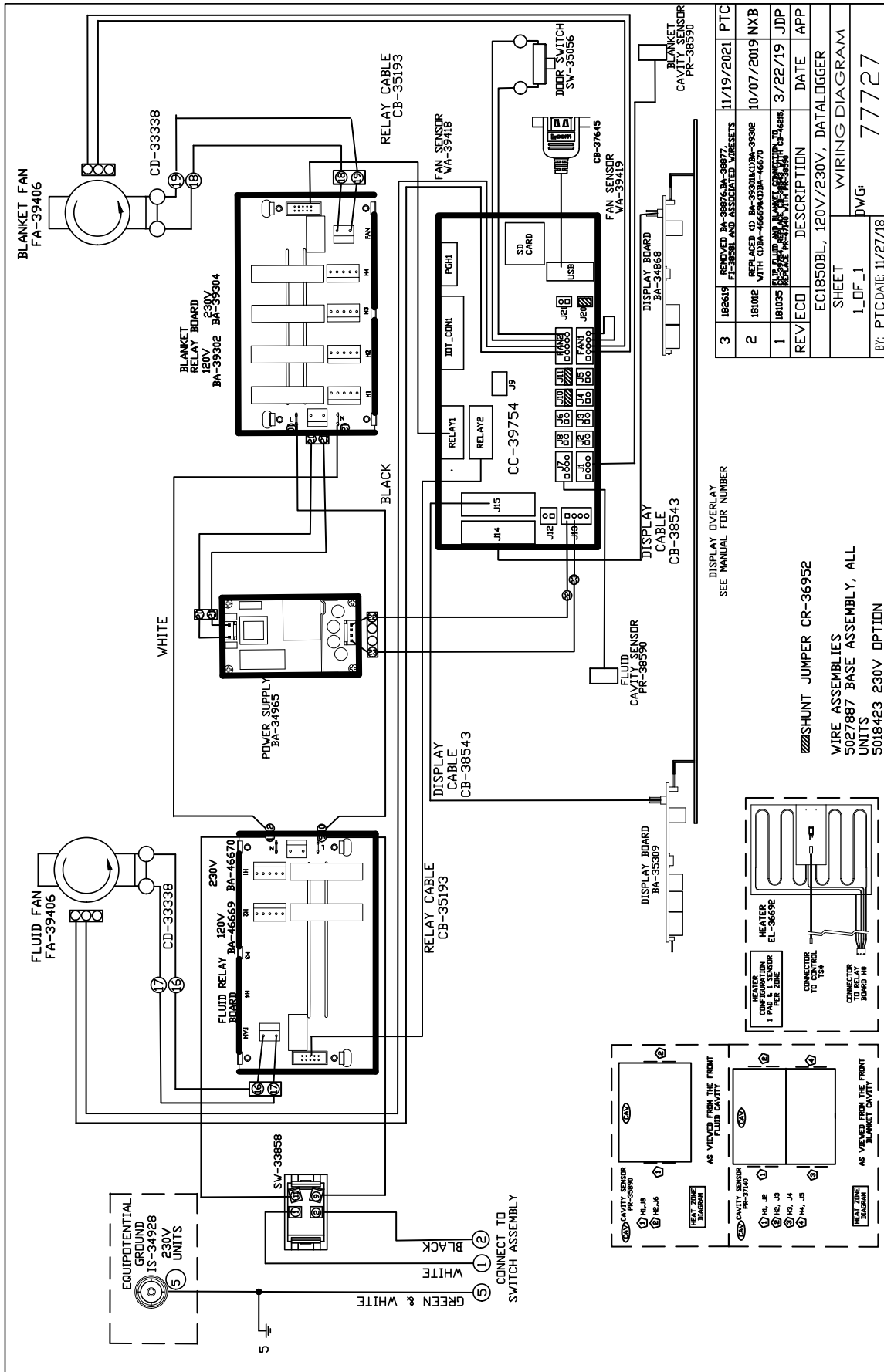

REV	DESCRIPTION	DATE	APP
3	REMOVED BA-38876, BA-38877, FL-38581 AND ASSOCIATED WIRESETS	11/19/2021	PTC
2	REPLACED CD BA-39302/BA-39308 WITH CD BA-46659/CD BA-46670	10/07/2019	NXB
1	ELP FLUID AND BLANKET CAVITY SENSORS	3/22/19	JDP

EC1850BL, 120V/230V, DATALOGGER	DATE	APP
1_DF_1	DATE	APP
1_DF_1	DATE	APP

BY: PTC DATE: 11/27/18

DISPLAY OVERLAY
SEE MANUAL FOR NUMBER

SHUNT JUMPER CR-36952
WIRE ASSEMBLIES
5027887 BASE ASSEMBLY, ALL
UNITS
5018423 230V OPTION

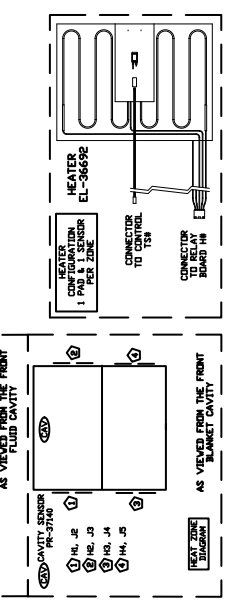

Serial number is required for all inquiries.

Part numbers and drawings are subject to change without notice.